



Construction

Close-coupled peripheral pump (regenerative pump) with turbine impeller. Compact, patent pending construction with single-piece motor casing and pump-side wall. Protected against water entering the motor from outside.

Applications

For clean liquids without abrasives, without suspended solids, non-explosive, non-aggressive for the pump materials. For increasing network pressure (follow local specifications). For the reduced dimensions, these pumps are very well suitable to be mounted in cooling and air-conditioning machines and equipments, circulation.

Operating conditions

Liquid temperature up to 60° C.
Ambient temperature up to 40° C.
Total suction lift up to 7 m.
Continuous duty.

Motor

2-pole induction motor, 50 Hz (n = 2900 rpm).

CT 61: three-phase 230/400 V ± 10%.

CTM 61: single-phase 230 V ± 10%, with thermal protector. Capacitor inside the terminal box.

Insulation class F.

Protection IP 54.

Constructed in accordance with: EN 60335-2-41.

Materials (wetted parts)

Components	CT 61	B-CT 61
Pump casing	Cast iron GJL 200 EN 1561	Bronze G-Cu Sn 10 UNI 7013
Pump-side motor wall	Brass P- Cu Zn Pb 2 UNI 5705	
Impeller	Brass P- Cu Zn Pb 2 UNI 5705	
Shaft	Chrome steel AISI 430	
Mechanical seal	Carbon - Ceramic - NBR	

Special features on request

- Other voltages.
- Frequency 60 Hz (as per 60 Hz data sheet).
- Protection IP 55.
- Special mechanical seal.

Coverage chart $n \approx 2900$ rpm

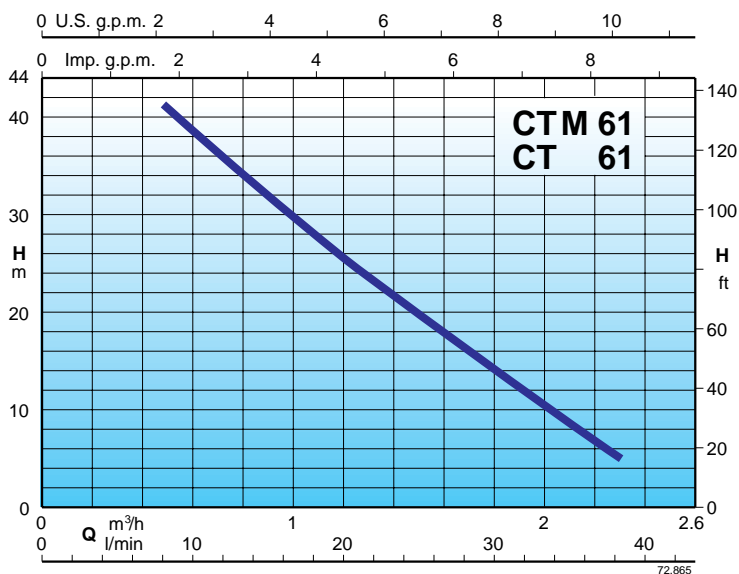

Performance $n \approx 2900$ rpm

3~	230V		1~	230V		P ₂		Q							
	A	A		A	kW	HP	m ³ /h	0,48	0,6	0,75	0,96	1,2	1,5	1,89	2,3
CT 61	1,9	1,1	CTM 61	2,5	0,33	0,45	H m	41	38,5	35,5	31	25,5	19	11	5
B-CT 61			B-CTM 61					8	10	12,5	16	20	25	31,5	38

H Total head in m.

P₂ Rated motor power output.

Dimensions and weights

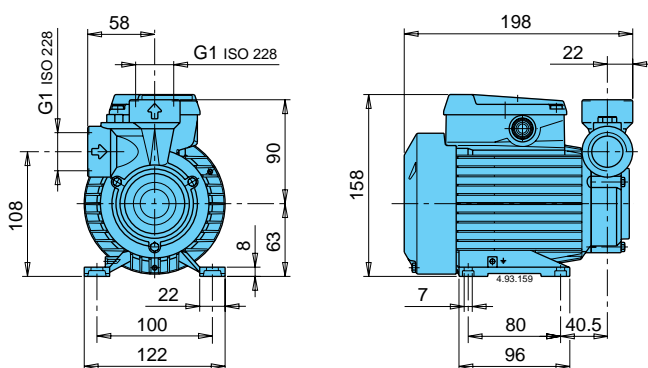

CT 61 **4,9** kg
 CTM 61 **5** kg
 B-CT 61 **5,1** kg
 B-CTM 61 **5,2** kg

Features

