



### Construction

Close-coupled peripheral pumps (regenerative pumps) with turbine impeller.

### Applications

For clean liquids without abrasives, without suspended solids, non-explosive, non-aggressive for the pump materials.  
For increasing network pressure (follow local specifications).  
For the reduced dimensions, these pumps are very well suitable to be mounted in cooling and air-conditioning machines and equipments, circulation, boiler feed.

### Operating conditions

Liquid temperature from -10 °C to +90 °C.  
Ambient temperature up to 40 °C.  
Total suction lift up to 7 m.  
Continuous duty.

### Motor

2-pole induction motor, 50 Hz (n = 2900 rpm).

**T, TP:** three-phase 230/400 V ± 10% .

**TM, TPM:** single-phase 230 V ± 10% with thermal protector.  
Capacitor inside the terminal box.

Insulation class F.

Protection IP 54.

Constructed in accordance with: IEC 34; IEC 335-1 (EN 60335-1).

### Materiales

Components	T, TP	B-T, B-TP
Pump casing	Cast iron	Bronze
Lantern bracket	GJL 200 EN 1561	G-Cu Sn 10 UNI 7013
Casing cover	Cast iron	Bronze
	GJL 200 EN 1561	G-Cu Sn 10 UNI 7013
Impeller	Brass P- Cu Zn Pb 40 2 UNI 5705 for T 61-65-70, B-T 61-70	
	Brass P- Cu Zn 40 Pb 2 UNI 5705 Bronze G-Cu Sn 10 UNI 7013 for T 125, TP 132-132R	
Shaft	Cr-Ni steel AISI 303 T 76, Tp 80-100	Cr-Ni-Mo steel AISI 316
	Chrome steel AISI 430 T 61-65-70-100-125, Tp 78-132-132R	
Mechanical seal	Carbon - Ceramic - NBR	

### Special features on request

- Other voltages.
- Frequency 60 Hz (as per 60 Hz data sheet).
- Protection IP 55.
- Special mechanical seal.
- Higher or lower liquid or ambient temperatures.

### Coverage chart $n \approx 2900$ rpm

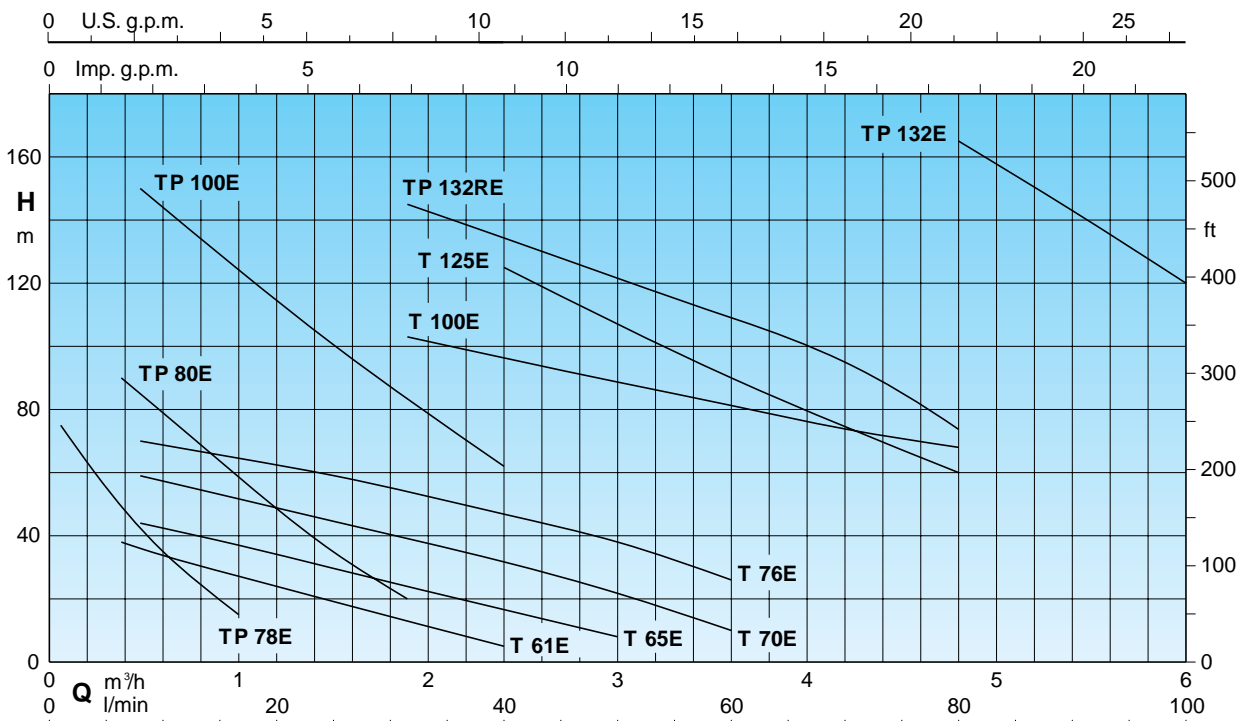

### Performance $n \approx 2900$ rpm

	3 ~ 230V 400V		1 ~ 230V	P <sub>1</sub>		P <sub>2</sub>		Q m <sup>3</sup> /h l/min	H m																	
	A	A		A	kW	kW	HP		0,06	0,12	0,24	0,38	0,48	0,6	0,75	1	1,2	1,5	1,89	2,4	3	3,6	4,2	4,8	5,4	6
B-T 61E	1,9	1,1	B-TM 61E	2,5	0,55	0,33	0,45																			
T 65E	3	1,7	TM 65E	3,5	0,8	0,45	0,6					38	36	34	31,5	28	24	19	12,5	5						
B-T 70E	3,7	2,2	B-TM 70E	6	1,3	0,75	1						44	42	40	37	33	29	24	16	8					
T 76E	5,3	3	TM 76E	7,4	1,6	1,1	1,5						59	57	55	51	48	43	38	30	22	10				
T 100E	11,5	6,6											70	68	67	65	62	58	53	46	38	26				
T 125E		9,5																	103	97	89	82	75	68		
B-TP 78E	2,3	1,3	B-TPM 78E	2,8	0,6	0,37	0,5													125	110	90	75*	60*		
B-TP 80E	4	2,3	B-TPM 80E	5,8	1,2	0,75	1																			
TP 100E	9,6	5,5				2,2	3																			
TP 132RE		12				5,5	7,5																			
TP 132E		16				7,5	10																			

P1 Maximum power input.

B-T, B-TM = Bronze construction.

H Total head in m.

\* Maximum suction lift 2-3 m.

P2 Rated motor power output.

### Dimensions and weights

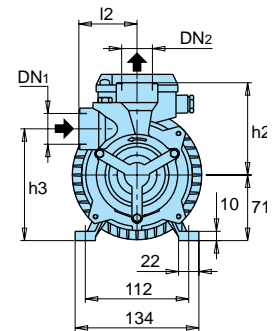
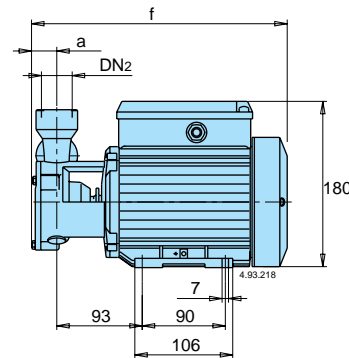
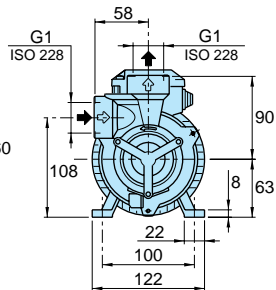
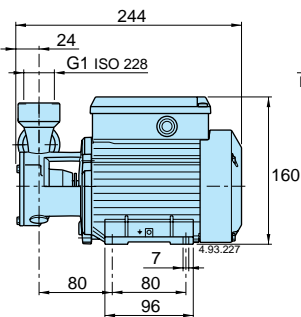

T 61E: kg 6,3  
B-T 61E: kg 6,5  
T 65E: kg 6,3

TYPE	DN1 ISO 228	DN2 ISO 228	mm					kg	
			a	f	h2	h3	l2	T	B-T
T 70E B-T 70E	G 1	G 1	24	278	100	121	63	11,2	11,6
TP 78E B-TP 78E	G 1/2	G 1/2	22	276	80	127	56	8,2	8,8

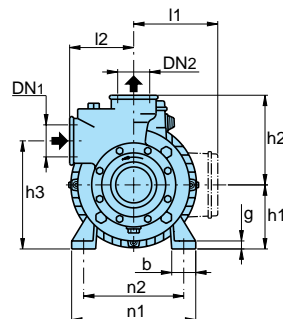
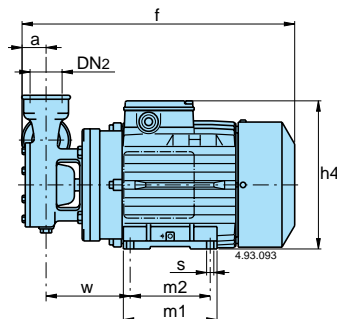

TYPE	DN1 ISO 228	DN2 ISO 228	mm																kg	
			a	f	h1	h2	h3	h4	m1	m2	n1	n2	b	s	l1	l2	w	g	T, TP	B-TP
T 76E	-	G 1 1/4	26	338	80	112	136	185	117	100	155	125	30	9	-	80	105	10	18,4	-
T 100E	-	G 1 1/4	32	405	90	130	161	216	152	125	180	140	40	9,5	-	95	121	12	29,5	-
T 125E	-	G 1 1/4	32	465	90	155	170	216	152	125	180	140	40	9,5	-	90	195	12	39	-
TP 80E B-TP 80E	G 3/4	G 3/4	27	332	80	90	135	185	117	100	155	125	30	9	-	60	104	10	16,4	16,8
TP 100E	-	G 3/4	27	347	80	100	142	185	117	100	155	125	30	9	-	65	113	10	21,3	-
TP 132RE	-	G 1 1/4	42	485	112	160	202	-	180	140	230	190	50	11,5	170	100	183	14	52,6	-
TP 132E	-	G 1 1/4	42	485	112	160	202	-	180	140	230	190	50	11,5	170	100	183	14	58	-

### Characteristic curves $n \approx 2900$ rpm

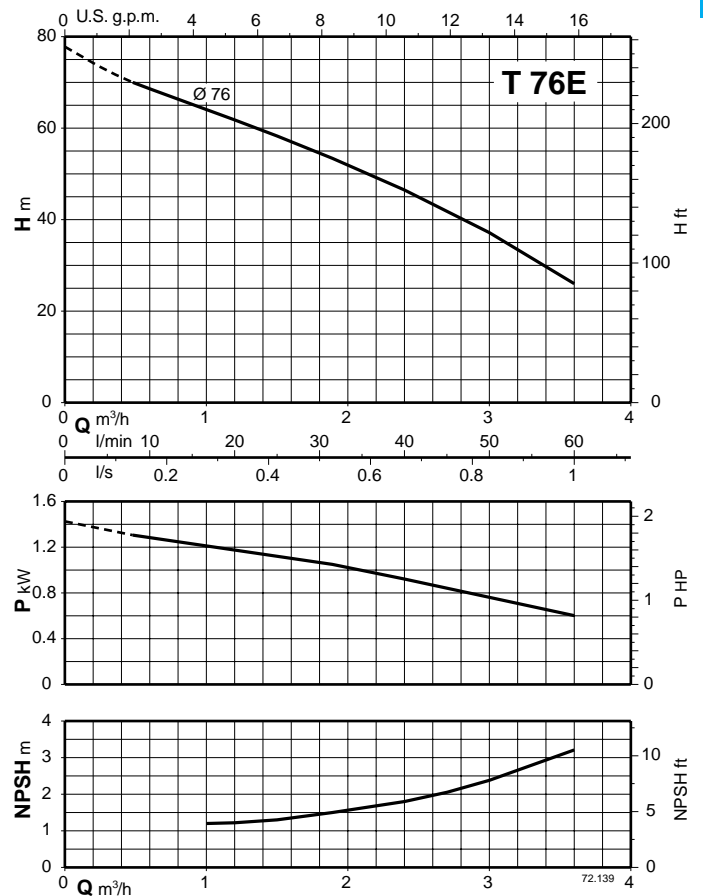
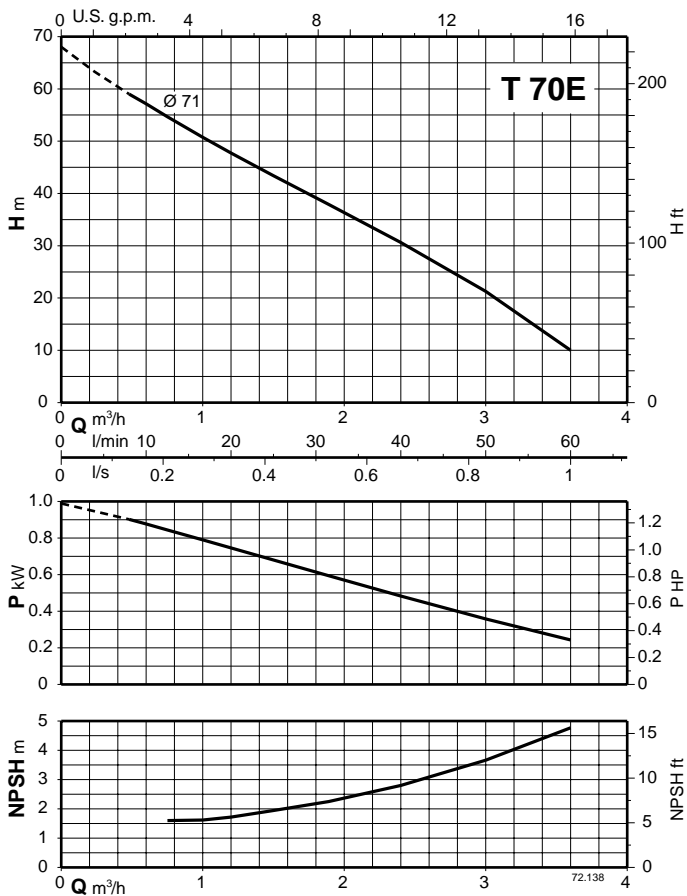
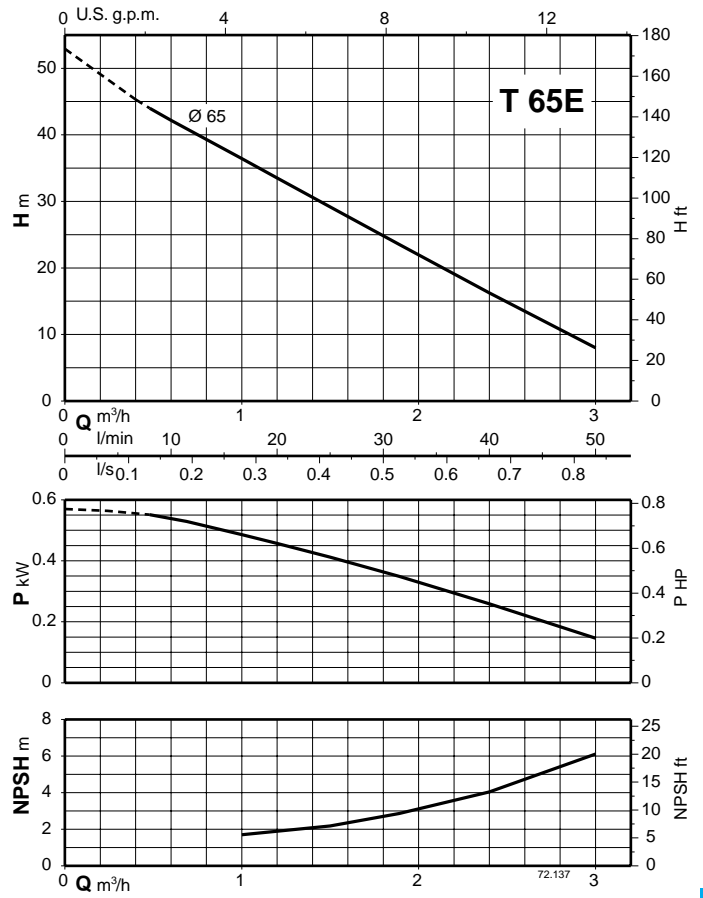
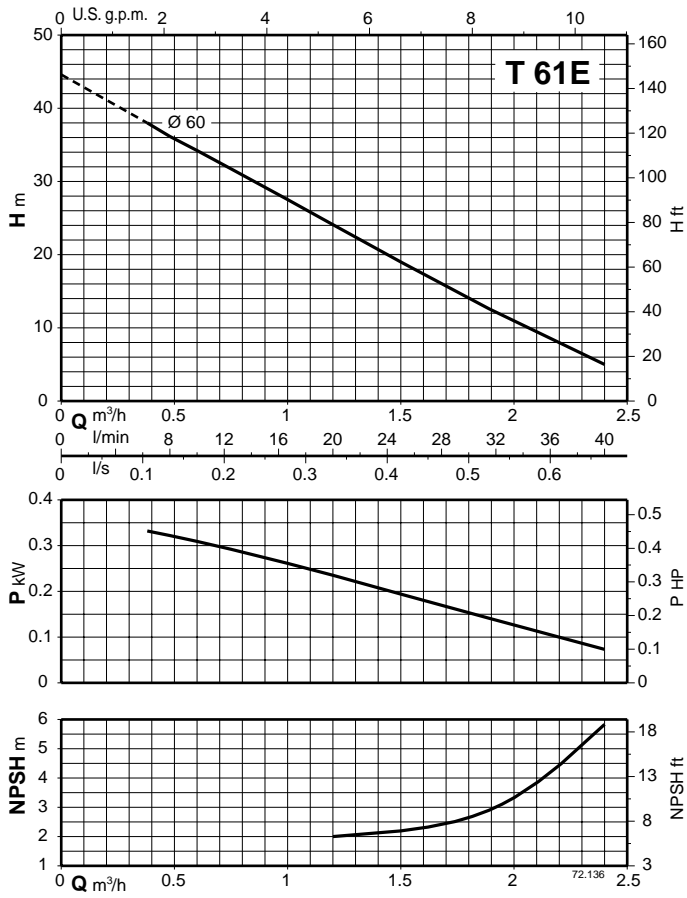

### Characteristic curves $n \approx 2900$ rpm

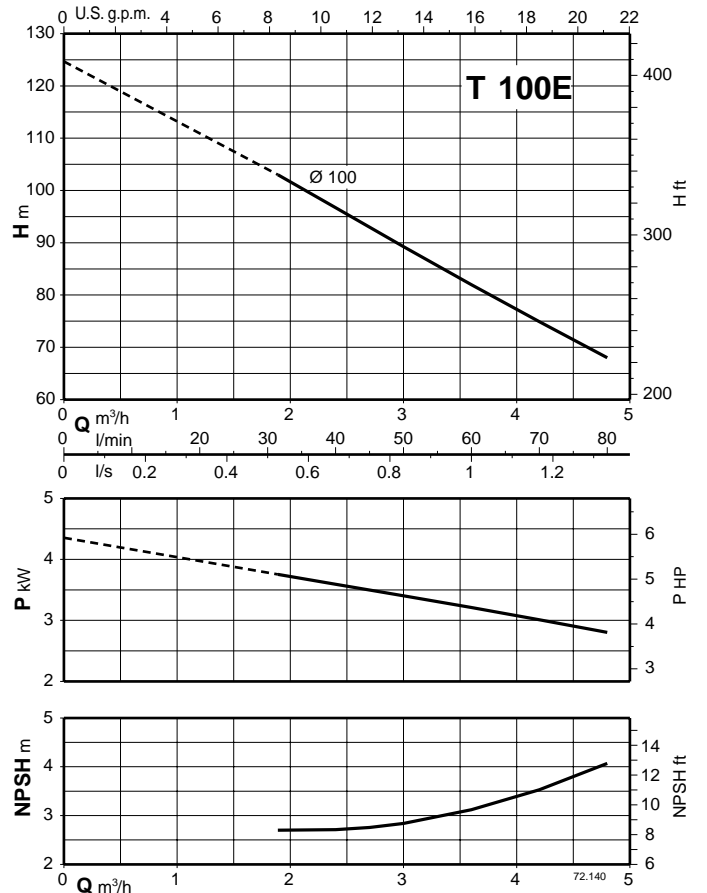
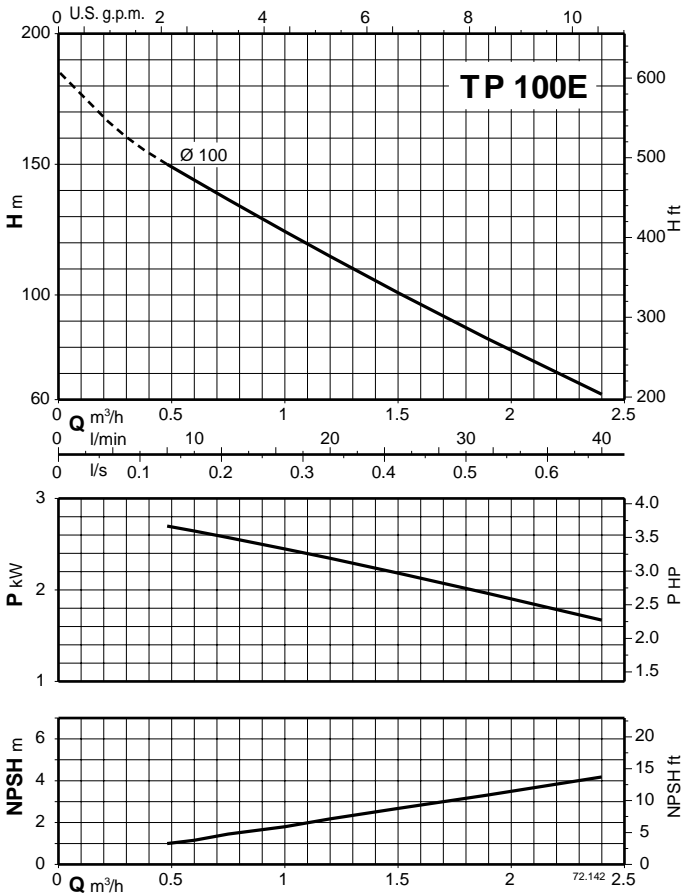
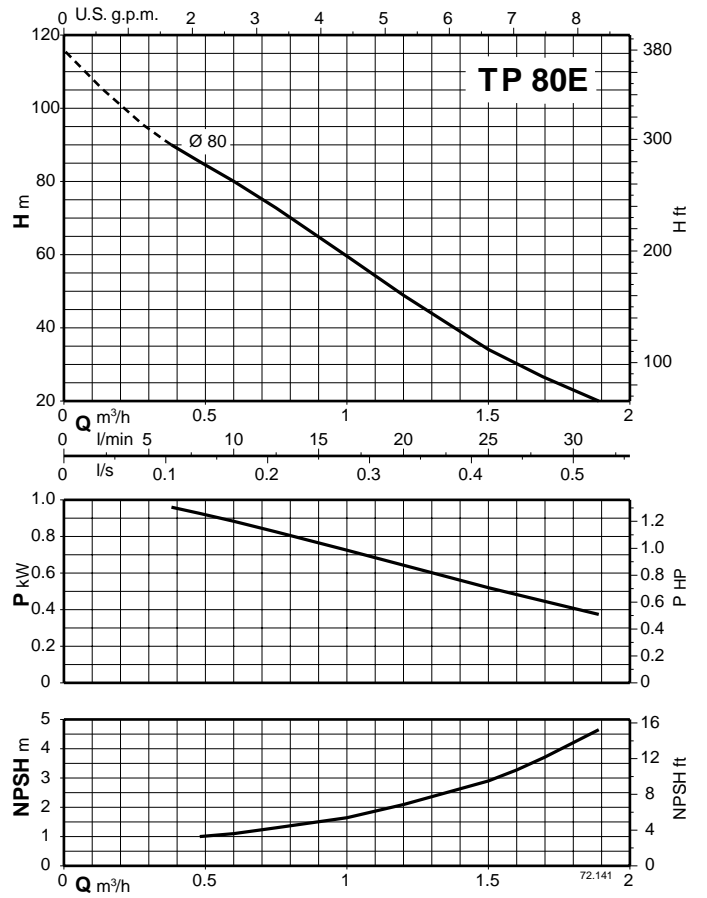
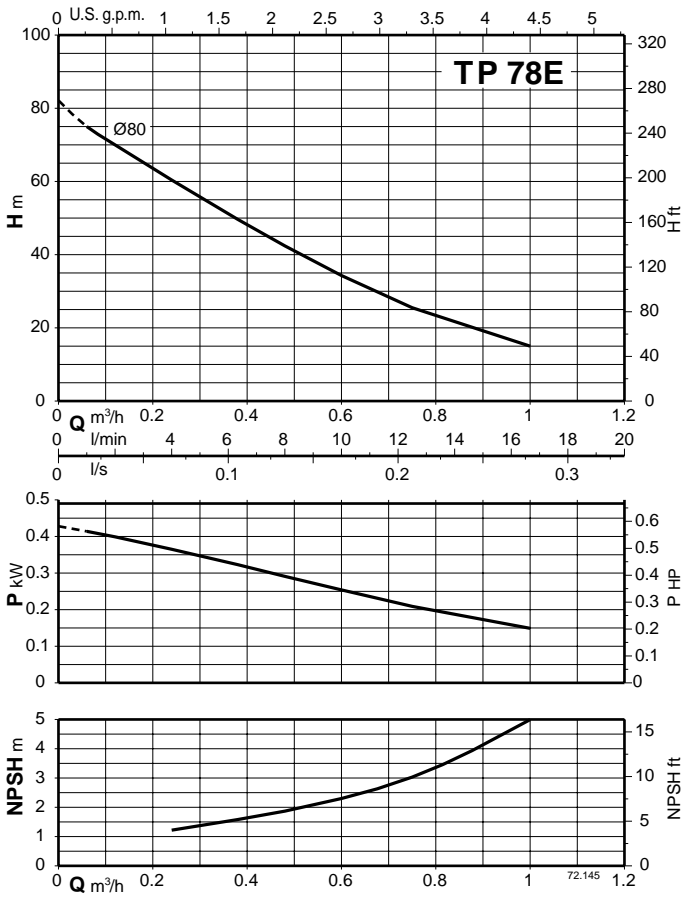

### Characteristic curves $n \approx 2900$ rpm

